

SAGA-420I

SAGA-720I/IP

SAGA-1350I/IP

SAGA-420II/IIP

SAGA-720II/IIP

SAGA-1350II/IIP

SAGA-1750II/IIP

Congratulations on purchasing saga cutting plotter

NOTICE:

We reserve the right to modify the information contained in this user manual at any time without prior notice; un-authorized modification, copying distribution is prohibited. All comments, queries or suggestion concerning this manual please consult us.

Please read this guide carefully. It tells you how to prepare your cutting plotter for production use in a few easy steps. We do not assume any liability for direct or indirect damage that occurs due to the use of this product.

Precautions:

Please read these instructions and precautionary notes carefully before using the machine for the first time .

- Don't place magnetic objects near the cutting head as even contact pressure can't otherwise be guaranteed.
- Don't unplug the connection to the computer lead line when the plotter is running ,may cause damage to plotter.
- Please release the pressure contact rollers when not in use by flipping the pressure levers up.
- Please keep your hands or other parts of the body far from carriage when using the machine.
- Never open the machine case and don't attempt to modify the machine.
- Avoid liquid spills and metal objects entering the interior of the cutter.
- Insure the power supply is grounded.
- Ensure the main power supply (220V/110V) doesn't fluctuate by more than $\pm 10\%$. In case of main power fluctuation, use a voltage stabilizer.
- Unplug the power lead during long periods of inactivity.
- Keep your hands well away from the blade holder while a carriage job is running!
- Always cancel the active job before adjusting the blade holder!
- Keep cutting plotter away from children, and never leave the machine or machine parts unattended when Plugged-in.
- Whenever never touch the tips of drag blade to avoid injury.
- Please set up the machine on a stable base to avoid danger of falling.
- Never run the machine during a thunder storm; lightning could damage or destroy the machine.
- No matter when you don't use hand move the carriage, in order to avoid damage to the machine.

2.What's in the box

Please check immediately to ensure that you have received the following articles:

- Cutting plotter
- Cutting plotter stand (dismantled)
- Power Lead
- USB connection Lead
- RS-232connection Lead
- Blade holder
- Pen holder and pen
- Safety fuse
- 3 Drag blade
- CD with software and drivers.
- 1Spanner ,1 hex key

3.Floor Stand Installation (720,1350,1750) ,

Step1

Position the support for the left side perpendicularly to bottom stand and place the screw into the holes.Tighten them to form a left T-stand .Repeat the same steps with the support for the right side

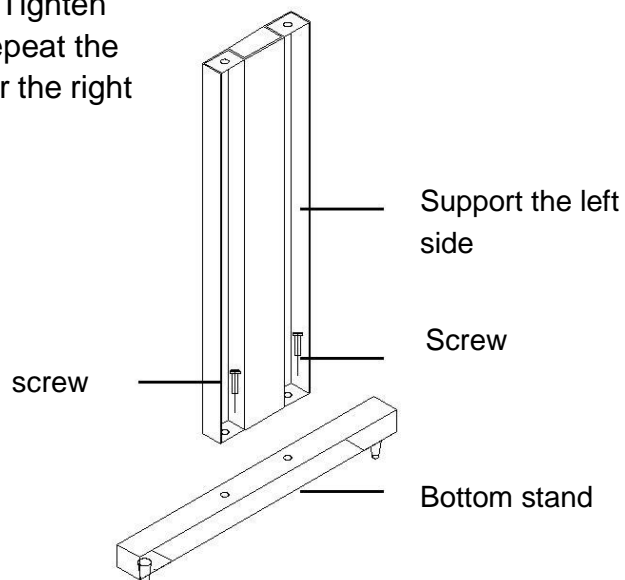

Step2

Place the stand beam upright on the T-stand and put the screws into the holes,but don't tighten them at this step.Repeat the same steps with another stand beam.

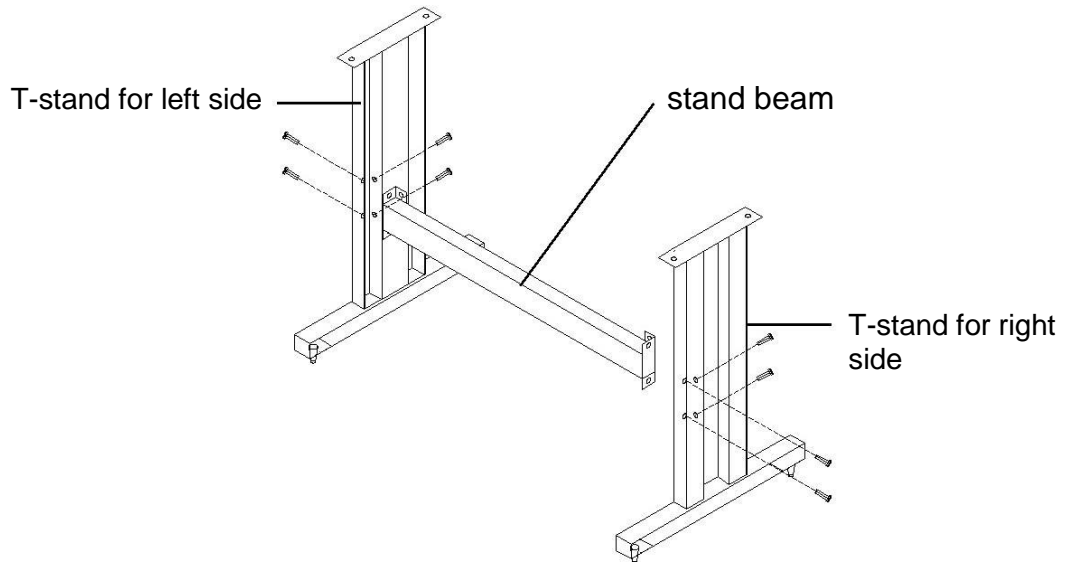

Step3

Position the roll holder support's position to floor stand ,and tighten screws.

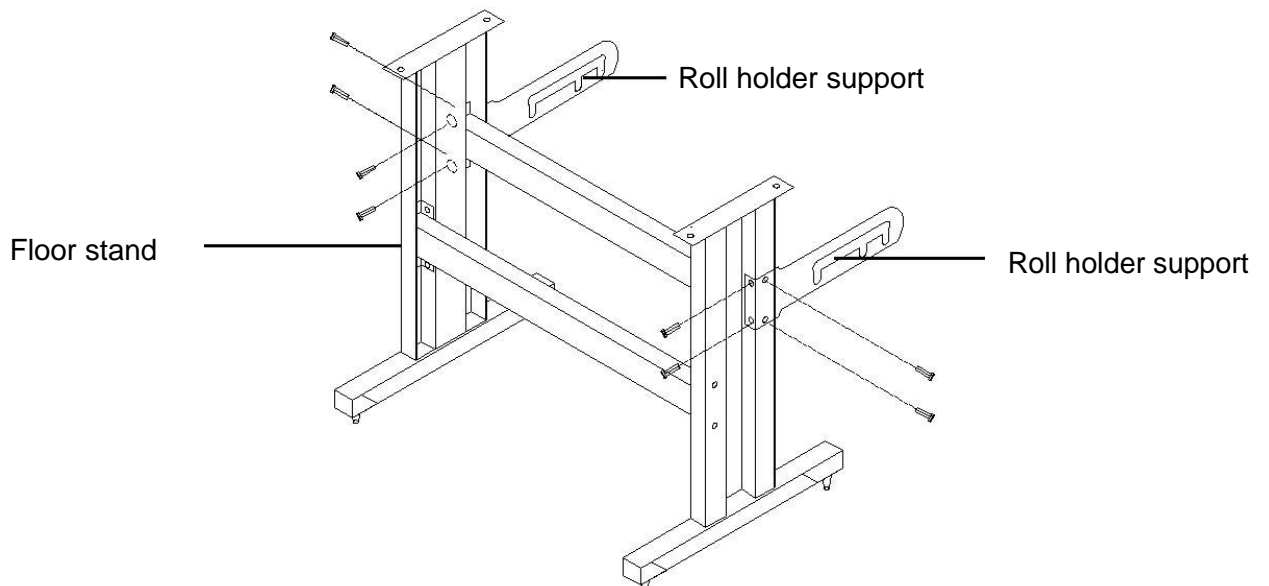

Step4

Place two roll holders into the holes in the roll holder support.



Specialized in developing,designing and manufacturing kinds of vinyl cutter

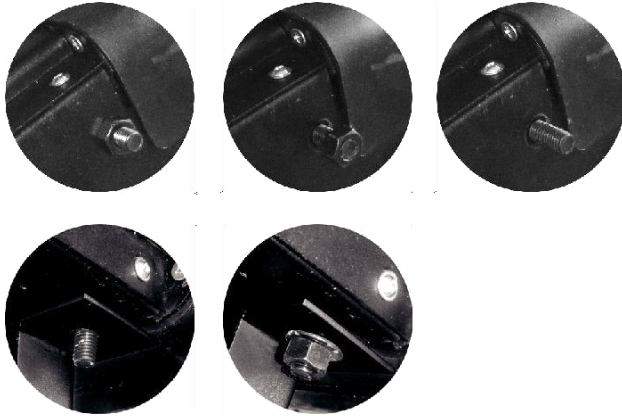

Take off the screw from bottom of machine,insert bolt to top of floor stand.

4.Blade installation

Caution :

Don't touch the tip of the blade with your fingers.

Notice

The blade is a consumable item,and you'll always get the best quality cut with a newer blade.please

Replace with a new blade when:

- 1.the tip of blade is broken.
- 2.The cutting traces are not as good as they were.
- 3.The blade will not cut cleanly even though the Blade force has been raised significantly.

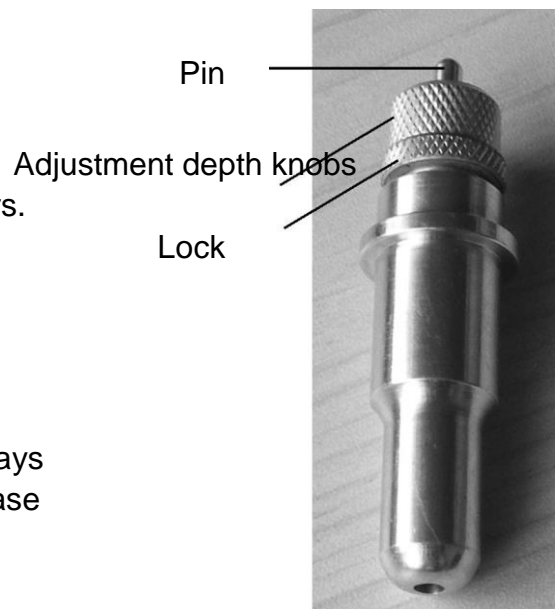

Step1/step2/step3

- 1.Push the blade to the bottom of the blade holder.
- 2.Adjust the blade tip to suitable length by rotating"Adjustment depth knobs"and then tighten the lock.
- 3.Press the push-pin to remove the blade form the blade holder when replacing blade.



step1



step2



step3

what is the correct blade depth

The correct blade depth ,blade just carve a post-it note surface layer, and won't carve the post-it note on the back, usually is 0.1 mm,



Correct depth



too long



too short

Different post-it is difference blade depth,please according to difference post-it choose difference blade depth.

Specialized in developing,designing and manufacturing kinds of vinyl cutter

Step 4

Will seat in the carriage on the right side of the blade holder, and to fasten on blade holder.



1、Cutting plotter appearance

5.1 front

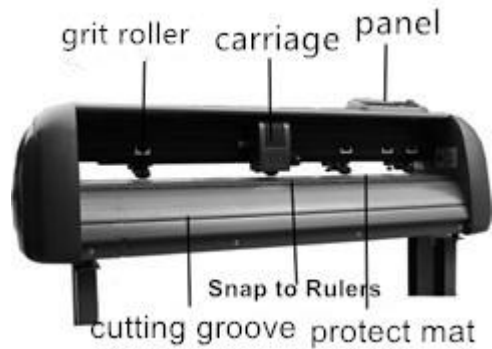

5.2 on the back



5.3 left-cap



Power switch
Power connector

5.4 right-cap



serial line connector (RS-232)
USB connector

5.5 Panel



5.6 Panel function

LCD screen: to display function and error messages.

Reset: to restart

Option: function keys.

Set: to set up function, can change XP/YP, Tool offset, sensitivity.

Test: to perform cutting tests in different ways.

Laser: On/Off laser.

▲ Speed: to adjust the value of cutting speed and quality up.

▼ Speed: to adjust the value of cutting speed and quality down.

◀ Force: to adjust the value of cutting force up.

▶ Force: to adjust the value of cutting force down.

Enter : to set item or register the immediately preceding input value.

2.installing and testing

6.1 set cutting plotter

- Please insure that the machine on flat,solid ground ,keep using the environment clean and dry .
- The machine suitable for 110V/220V voltage, Please be sure to use and the corresponding voltage matching.
- Turn on the power switch ,the carriage will automatically move to the right and left and then stop when switched ON.if you need to adjust position of the carriage,Please according to the panel adjust to position of the carriage,never use your hands move carriage

6.2Please as following machine USB lead and com cable (RS-232) ,connector cutting plotter and computer.

6.2-1 Installing the USB lead , USB2.0

The lead suitable for MAC,Windows2000/2007and Windows XP .
Nonsupport Windoes95/98/Me system.

Please make sure that the machine supporting the use of software.,such as Dragoncut software, Flexi software, Artcut, signcut etc .

6.2-2 How to installation USB print driver

Notice: Please install the USB print driver then connector the cutting plotter.

- Double-lick the CD in the setup. exe, the computer will automatically install the USB driver as a new portCOM1or COM2
- Connect the USB lead to the cutting plotter and the computer USB port .
- Windows will detect the cutting plotter and install the USB printing driver automatically,please be patient and give Windows sufficient time to recognition and install the driver.
- If is a 32 bit system can be installed directly, if it is a 64bit system, please install as administrator.
- Please check for the driver in Device manager under universal serial .Bus controllers/USB printing support.If the (USB printer support driver) does not appear,please re-check the power and of the USB lead connection and ensure the plotter is switched on.

6.3 How to use software

6.3-1How use and install Artcut software , Please refer to the artcut instructions.

6.3-2How to use and install Signcut software, Please refer to the signcut software instructions.

6.3-3How to use and install Dradoncut software, Please refer to the Dragoncut software instructions.

6.3-4How to use and install Flexi software , Please refer to the Flexi software instructions.

6.3-5How to use the external program, please refer to the external program instructions.

6.4Loading media

- Always load media for processing from the rear of the machine.
- Pull the pinch roller level upward to raise the pinch rollers, load your media on the platen and slide it under the pinch rollers .Move the pinch rollers manually to the proper position. Be sure the pinch rollers are positioned above the grit roller.The white marks on top trail will help you position pinch rollers when media on the platen.push the pinch roller level downward to lower down the pinch rollers.
- If you are using roll media rather than precut media,use the supplied roll holder to ensure that the media unrolls smoothly.
- When loading media ,ensure that the media is straight to avoid warping when transporting the media .A misalignment of just a few millimeters can cause severe media warp in longer plots.
- You can load the media at any horizontal position in the machine ;it does not matter whether the media is centered,or aligned on the left or right.
- Fix the pressure rollers by snapping them into place at the outer edges of the media;this ensures straight feeding of the media and defines the maximum cutting area.

6.5setting the zero point

The zero point is the point on the loaded media where the plot job will start.You need to set the zero point whenever you switch the machine on,or after loading media for processing.

Specialized in developing,designing and manufacturing kinds of vinyl cutter

- Switch the cutting plotter on,when the cutting plotter is switched on, the cutting plotter can be changed and modified as required.
- To change the zero point on,when the cutting plotter is switched on, the carriage can be changed and modified as required.
- You can now adjust the zero point setting for your cutting plotter,first press the On/Off key to toggle to Off mode.
- You can now adjust the zero point by pressing the four arrow keys..We recommend setting the zero point to the front right corner of the media.While the carriage moving,the current coordinates are display relative to the previous zero point setting.
- Press Enter to confirm the new zero point setting .
The coordinates shown in the display are set to zero.

6.6 Setting Mode

You can press the mode key multiple times in off mode toggle through the following menus:

Force

Use the Left/Right keys to set the force in unites of one gram ;the valid range of values is between 0g and 750g(servo) or 0g and 510g (stepper),2g/step.

When setting the cutting force ,please note that the correct setting mainly depends on the blade holder, the position of the blade ,and the loaded media.These settings are subject to variation.**Before work you can press the test button to test.**

Speed :

Again use the UP/Down keys on the operating panel to set the speed.

X-Scale/Y-Scale

Don't change the X-Scale or Y-Scale values as they are used to compensate for wear and tear of the transport belts.Only change these settings,if plots come distorted..

Baud Rate:

The Baud Rate is the communication speed for the cutting plotter and the serial port on your computer.This setting must reflect the baud rate set in the properties dialog for your COM port.Or in the software Value of 38400 are typically set.

XP/YP :

Don't need to change.

Sensitivity) :

Is based on the reflective intensity of paper to adjust, the reflective strength is small value and he reflective weak is bigger value.

Fan setting:

ARMS machine use it ,can adjust the wind size of fan .

Additional setting in the display :

NO/Off (pause the plot)

Press this key to pause the current plot;you can then modify settings performed previously.The display now shows the force and speed;both values can be modified.

If you want to pause of cutting ,you can press the test key,wanted to end work ,please press the reset key.

6.7cutting test

- Press the Test key to perform a cutting test.The cutting plotter will now cut a square containing a triangle divided into four quadrants.
- The cutting test helps you verify the blade holder setting and cutting pressure.The cutting test should give you clean and straight cuts in the loaded media;there should be no damage to the backing
- If the test cuts through the backing,either the cutting force is too high,or blade or blade holder setting is incorrect.Change these setting and repeat the cutting test.
- You will also need to change the settings, in case of imprecise or too shallow cuts.

7.After cutting

7.1.Weeding

Weeding refers to the process of removing the parts of the media you don' require.

We recommend using a scalpel or a spacial weeding tool for this job,to avoid damage to the adhesive surface.After weeding, You can use a transfer press to transfer flock and flex media to the textiles to be processed;apply application tape to self-adhesive media before transferring.



7.2.Apply

Apply application tape to the weeded material and use a roller or flat scraper to press down firmly.To apply adhesive to the transfer foil,remove the backing from the foil to leave the adhesive affixed to the application tape.You an now apply the adhesive to the required surface.

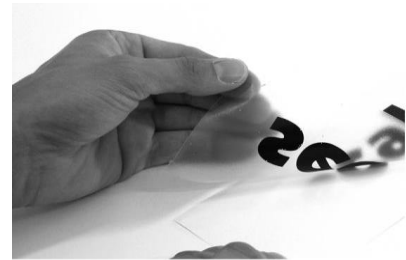

8.Blade

Blade are extremely sensitive,extremely sharp and dangerous precision tools.

- Always keep blade well out the reach of children.
- To avoid danger of injury,always handle blade with caution.
- Handle blade with caution and always replace the protective cap when not in use.If the tip of the blade comes into contact with a hard material such as following glass or stone,tiny fissures may occur at the blade tip making the blade useless.Note the following to avoid unnecessary wear and tear the blade and to ensure maximum working life.
- Avoid cutting the backing of loaded media.The deeper you cut into the loaded material,the more wear and tear the blades are exposed to.
- Always set the cutting depth of the blade to cut the media precisely and cleanly without cutting too deep.Extending the blades beyond the required cutting depth impacts the service life of the blades without achieving better cutting results.
- Always use the right custom blades for thicker material.
- Ragged edges on cutting the loaded media show that the blades are blunt.Always replace blunt blades immediately.

9.Basic maintenance

9.1Cleaning the cutting plotter

In order to keep the cutting plotter under good condition and best performance,you need to clean the machine properly and regularly.

Precaution in cleaning

Unplug the cutting plotter before cleaning.Never use solvents,abrasive cleaners or strong detergents for cleaning.They may damage surface of the cutting plotter and moving parts.

Recommended Methods

- Gently wipe the cutting plotter surface with a lint-free cloth.If necessary,clean with a damp cloth or an alcohol-immersed cloth.Wipe with water to rinse off any residue and dry with a soft,lint-free cloth.
- Wipe all dust and dirt from the tool carriage rails.
- Use a vacuum cleaner to empty any accumulated dirt and media residue from beneath the pinch roller housing.
- Clean the platen,paper sensors and pinch rollers with a damp cloth and dry with a soft,line-free cloth.
- Wipe dust and dirt from the stand.

9.2Cleaning the grit roller

- Turn off the cutting plotter,and move the tool carriage away from the area needed to be cleaned.
- Raise the pinch rollers and move them away from the grit roller for cleaning.
- Use a bristle brush(a toothbrush is acceptable)to remove dust from the grit roller surface.Rotate the grit roller manually while cleaning.

9.3Cleaning the pinch rollers

If the pinch rollers need a thorough cleaning,use a lint-free cloth or cotton swab to wipe away the accumulated dust from the rubber portion of the pinch rollers.To prevent the pinch rollers from rotating while cleaning,use your finger to hold them in place.If needed to remove the embedded or persistent dust,Use the lint-free cloth or cotton swab moistened with rubbing alcohol.

Note :

Daily maintenance of your cutting plotter is very important, Be sure to clean the grit roller and pinch rollers regularly for better cutting accuracy and output quality.

10. Technical specifications cutting plotter

10.1 Servo ARMS machine technical specifications

Item NO.	SAGA-720IIP	SAGA-1350IIP	SAGA-1750IIP
Max media width	720mm	1350mm	1750mm
Max cutting width	630mm	1200mm	1660mm
Accuracy	+/-0,01m	+/-0,01m	+/-0,01m
Connectors	USB/RS-232	USB/RS-232	USB/RS-232
Drive	Servo	Servo	Servo
Power consumption	<100w	<100w	<100w
Ambient temperature	+5°C+35°C	+5°C+35°C	+5°C+35°C
Meas	97x34x43cm	160x34x41cm	207x36x51cm
G.W/N.W	27.5/25kgs	38/35kgs	52/47kgs

10.2 Stepper ARMS machine technical specifications

Item NO.	SAGA-720IP	SAGA-1350IP
Max media width	720mm	1350mm
Max cutting width	630mm	1200mm
Accuracy	+/-0,01m	+/-0,01m
Connectors	USB/RS-232	USB/RS-232
Drive	Stepper	Stepper
Power consumption	<100w	<100w
Ambient temperature	+5°C+35°C	+5°C+35°C
Meas	97x34x43cm	160x34x41cm
G.W/N.W	27.5/25kgs	38/35kgs

Specialized in developing, designing and manufacturing kinds of vinyl cutter

10.3 Servo machine technical specifications

Item NO.	SAGA-490II	SAGA-720II	SAGA-1350II	SAGA-1750II
Max media width	420mm	720mm	1350mm	1750mm
Max cutting width	330mm	630mm	1200mm	1660mm
Accuracy	+/-0,01m	+/-0,01m	+/-0,01m	+/-0,01m
Connectors	USB/RS-232	USB/RS-232	USB/RS-232	USB/RS-232
Drive	Servo	Servo	Servo	Servo
Power consumption	<100w	<100w	<100w	<100w
Ambient temperature	+5°C+35°C	+5°C+35°C	+5°C+35°C	+5°C+35°C
Meas	66×33×32cm	97×34×43cm	160×34×41cm	207×36×51cm
G.W/N.W	10/9kgs	27.5/25kgs	38/35kgs	52/47kgs

10.4 Stepper machine technical specifications

Item NO.	SAGA-420I	SAGA-720I	SAGA-1350I
Max media width	420mm	720mm	1350mm
Max cutting width	330mm	630mm	1200mm
Accuracy	+/-0,01m	+/-0,01m	+/-0,01m
Connectors	USB/RS-232	USB/RS-232	USB/RS-232
Drive	Stepper	Stepper	Stepper
Power consumption	<100w	<100w	<100w
Ambient temperature	+5°C+35°C	+5°C+35°C	+5°C+35°C
Meas	66×33×32cm	97×34×43cm	160×34×41cm
G.W/N.W	10/9kgs	27.5/25kgs	38/35kgs



Warm prompt:

If, in accordance with the instruction cannot complete the installation, testing, please contact your agent.